

noztek

Filament Winder

2

USER MANUAL



Introduction

Noztek proudly presents the Winder 2.0, a cutting-edge precision filament winding system meticulously engineered for speed, spooling precision, and user-friendly operation. The embedded touch screen offers an array of features for enhanced control over your winding process.

Choose between 'automatic' and 'manual' modes to seamlessly customise settings based on the materials you're working with. This unit is indispensable for Noztek extruder users. It effortlessly winds extruded filament onto a spool and is easily removable for direct use in your 3D printer, for palletizing, or any other application.

Housed in a robust metal or stainless steel chassis, this professional winding system boasts a top winding speed of 10 meters per minute. With a capacity to handle spools up to 2.2 Kg, the high precision linear drive and improved laser sensor algorithm ensure consistently neat and tangle-free results.

The system comes with two pre-set default spooling diameter settings for 1.75mm and 3mm filament, but manual adjustments in the settings allow flexibility from 0.5mm to 5mm.

Designed to integrate with our Filament Tolerance Puller, it's important to note that the Winder focuses on winding, while tolerance settings are managed by the Tolerance Puller. Elevate your winding experience with Noztek's advanced Winder 2.0.

Winder 2.0. manual

• WARRANTY	1
• SAFETY CAUTIONS	2
• SAFETY GUIDELINES	3
• PRODUCT SPECIFICATION SHEET	4,5
• SET-UP INSTRUCTIONS	6
• OVERVIEW	7
• OPERATION INSTRUCTIONS	9,10,11,12,13,14,15,16
• ADDITIONAL INFORMATION	16
• CONTACT	17

Warranty

We guarantee outstanding quality for our products and services.

Customers who purchase Noztek-manufactured equipment for professional use are guaranteed that they will be free from defects in workmanship and materials for 1 year from date of shipment. If your machine is found to be faulty, we will repair or replace the machine. The warranty and functional guarantee does not cover damages caused by wear and tear or improper use.

TO INSURE THAT YOUR WARRANTY IS HELD IN EFFECT, PROPER OPERATION PROCEDURES MUST BE OBSERVED.

NOTE: READ THE SAFETY PRECAUTIONS BEFORE OPERATING THIS MACHINE.

For a full breakdown please read our Limitations of Warranty Cover below.

Limitations of Warranty Cover:

- You must own the machine
- The original invoice is decisive as this is your warranty claim (please keep a copy of this)
- Repair or replacement of machine will be determined by Noztek
- Warranty only covers manufacturing or material defects

Warranty does not cover:

- Incorrect use of machine /damage due to misuse
- Damage from force or fall
- Foreign objects inside of machine
- Water damage or dirt
- User failing to follow proper usage instructions
- Normal wear and tear in machine's lifespan
- Unauthorized repairs by consumer

While we stand by the quality of our products, it's important to note that our liability is limited. This warranty represents your sole remedy, and there are no other expressed or implied warranties.

In the rare instance of a covered defect, we offer remedies such as repair or replacement after assessing the reported fault.

Noztek have the right to reject any warranty claim if we feel the request falls outside of our limitations

Filing a Claim:

Need assistance? Our customer support team is ready to help. Refer to the contact information provided in this manual to start the claims process.

Safety

Caution: Injury Risk

This equipment contains moving parts. To prevent injury, keep hands, fingers, and other body parts clear during operation. Avoid wearing loose clothing or jewellery that may become entangled in moving components. Tie back long hair and secure loose items before using the equipment. Always follow safety instructions provided in the user manual.

Caution: High Voltage Zone

This equipment contains high-voltage components. To avoid the risk of electrical shock:

Do not use liquids near the machine: Keep all liquids, including water, away from the equipment. Liquids can conduct electricity and increase the risk of electrical shock.

Do not modify internal wiring: Modifying internal wiring or electronic components poses a serious hazard. Only authorized personnel should perform any maintenance or modifications.

Safety guidelines

- Before operating, ensure you have a thorough understanding of the equipment. Carefully review the provided instruction manual for complete guidance.
- Understand the proper, safe usage and limitations of the equipment.
- Never use this equipment for any purpose other than its intended use.
- Do not modify the equipment in any way.
- Do not make adjustments or perform maintenance while the system is in operation or energized.
- Non-Flammable Cleaning: Refrain from cleaning the equipment with flammable solvents.

Product Specification Sheet

1. Product Information:

- Product Name/Model: Noztek Winder 2.0
- Brand/Manufacturer: Noztek
- Serial Number: See invoice
- Date of Manufacture: 2023

2. General Description:

- Noztek proudly presents the Winder 2.0, a cutting-edge precision filament winding system meticulously crafted for speed, spooling precision, and user-friendly operation. The embedded touch screen offers an array of features for enhanced control over your winding process.

3. Technical Specifications:

- Voltage Requirements: 220VC or 110VC
- Power Rating: 10A
- Frequency (Hz): 50 Hz or 60 Hz.
- Operating Temperature Range: -40°C to 85°C (-40°F to 185°F)
- Dimensions (including weight and size): 70cm x 38cm x 38cm. 10 KG.
- Material Composition: Steel or stainless steel.
- Color/Finish: Black powder coat or brush stainless steel.

4. Key Features:

Automatic mode

This user-friendly mode automates the winding process, requiring an initial setup to calibrate your filament and spool size. Perfect for seamless extrusion runs directly from your extruder.

Manual mode

This mode grants complete control over your winder speed settings, ideal for situations requiring a consistent winding speed, like re-spooling.

4.3-Inch TFT Touchscreen Control Panel:

The machine features a sophisticated 7-inch Thin-Film Transistor (TFT) touchscreen, providing an intuitive and responsive interface for operating and configuring the equipment.

5. Safety Information:

- Warnings: See safety sheet
- Recommended Safety Gear: See safety sheet
- Emergency Shutdown Procedures:

In the event of an emergency, firmly press the red emergency button located at the back of the machine. This action will swiftly deactivate the power supply, bringing all ongoing processes to an immediate halt.

6. Operating Instructions:

- Step-by-step instructions for safe and proper use of the product: See safety sheet and guide
- Start-up and Shutdown Procedures: See guide
- Control Panel Layout: See guide
- Maintenance and Cleaning Guidelines: See maintenance sheet.

7. Technical Diagrams:

- Available upon request.

8. Performance Data:

- Spooling speed: max. 10 meters a minute.
- Spool capacity: Up to 2.2 KG.

9. Accessories and Included Items:

- Mains cable
- Spare spool

10. Warranty Information:

- See warranty sheet.

11. Compliance and Certifications:

- CE

12. Technical Support and Contact Information:

- info@noztek.com
- <https://noztek.com/contact/>
- 44 (0) 203 384 6208

• Noztek Head office
Unit C3 Dolphin Enterprise Centre
Evershed Way
Shoreham
West Sussex
BN43 6QB
ENGLAND

Set-up Instructions

1. Unpacking and Placement:

Caution: Do not plug the machine into the mains or turn it on during set-up. Carefully unpack the machine and accessories. Place the machine on an even, stable surface.

2. Power Connection:

Once the initial steps are completed, you can plug in the mains cable into the machine. Before doing so, double-check that the mains voltage (e.g., 220VAC or 110VAC) matches the voltage specified on the machine (refer to the sticker on the machine). **Refer to the image below to locate the mains power inlet.**

Note: Always follow these set-up instructions meticulously to ensure the safe and effective operation of the machine. If you encounter any issues or have questions, refer to the comprehensive user manual for further guidance.

Image: Location of main power inlet

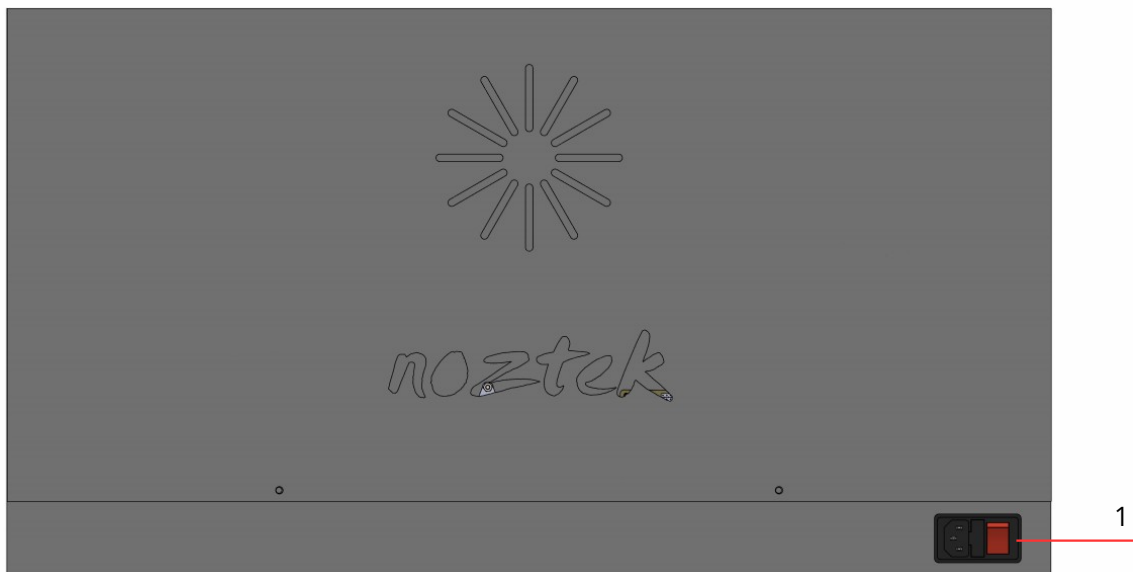

Power Connection

1. Mains socket inlet and power switch. (220VAC or 110VAC).

Overview Winder 2.0

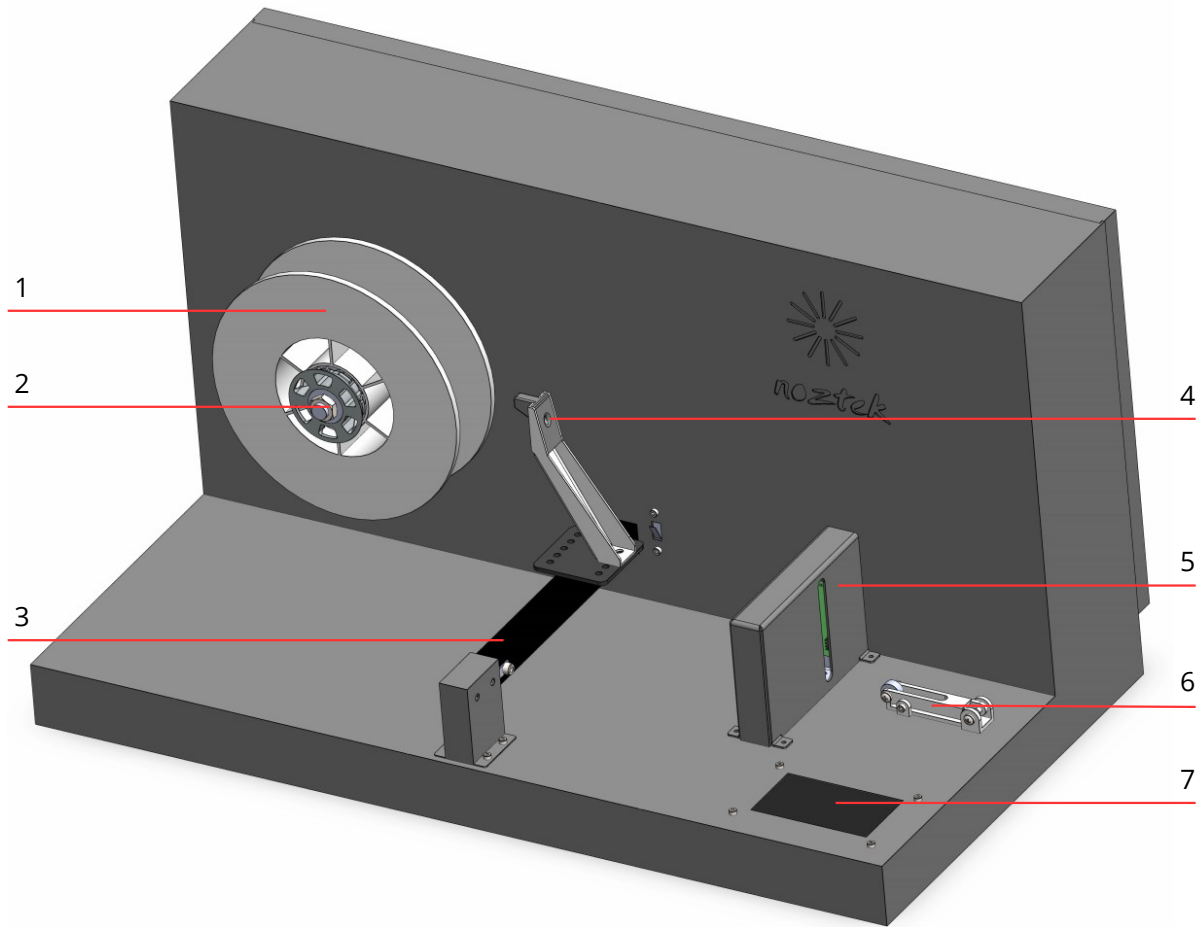

Overview main features winder 2.0

1. 1KG Spool.
2. Spool nut.
3. Linear drive.
4. Linear drive spool guide.
5. Laser filament height sensor.
6. Filament tensioner.
7. LCD screen.

Operation Instructions

Important Note:

The Winder 2 has no impact on filament tolerance; its sole purpose is to efficiently wind filament onto a spool.

STEP 1. Familiarization:

Familiarize yourself with the with the key features of Winder 2.0 as illustrated on page 7.

STEP 2. Start up procedure:

To turn on the machine, use the illuminated mains power switch located at the back as shown on page 6.

STEP 3. Main Screen overview:

The main screen features buttons for manual and automatic modes. Simply press the respective button to enter the desired mode. On the following page, you will find a comprehensive explanation of both operating modes.

Image: Main menu screen, auto and manual mode.

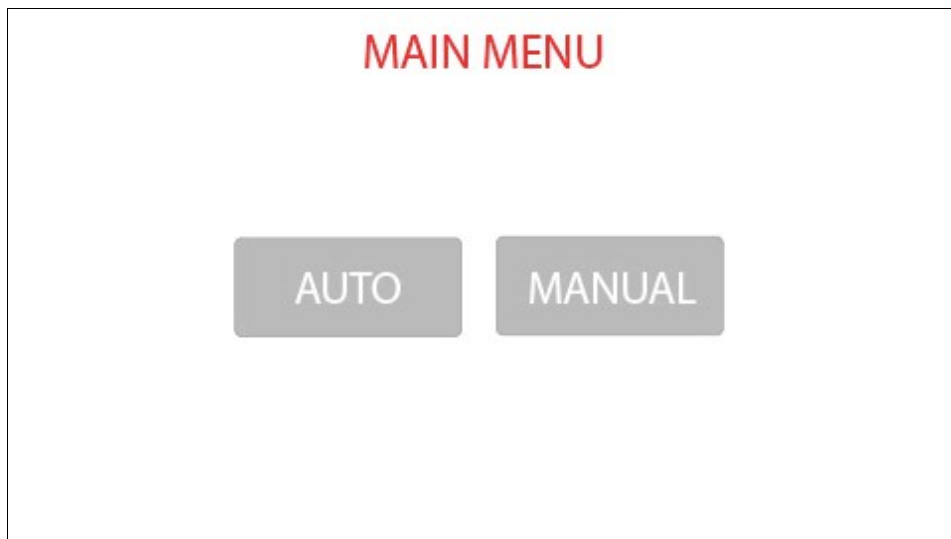

Manual Mode:

STEP 4.1. Manual mode - set guides:

On this screen (**Image 1**), you can manually calibrate the filament guide by adjusting it to match the width of your spool. The Winder 2.0 comes pre-calibrated for our 1 KG spools, allowing you to skip this step when using the supplied spools. However, if you're using different spools, customize the settings on this screen. The two values shown on the screen represent the two points on the linear driver where the guide moves (**Image 2**). To calibrate for a new spool, ensure the filament guide aligns with the left and right insides of the spool (**Image 3**). Input each value and press "SET" when the guide is in the correct position. These values will be stored for future use. Press the "NEXT" button to continue or "MAIN MENU" button to go back.

Image 1: Guide limit screen

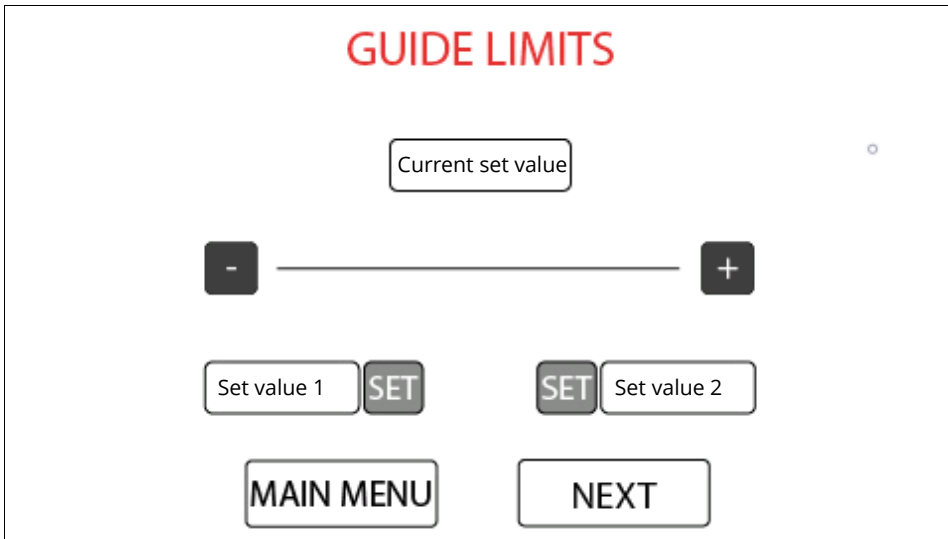

Image 2: Linear drive

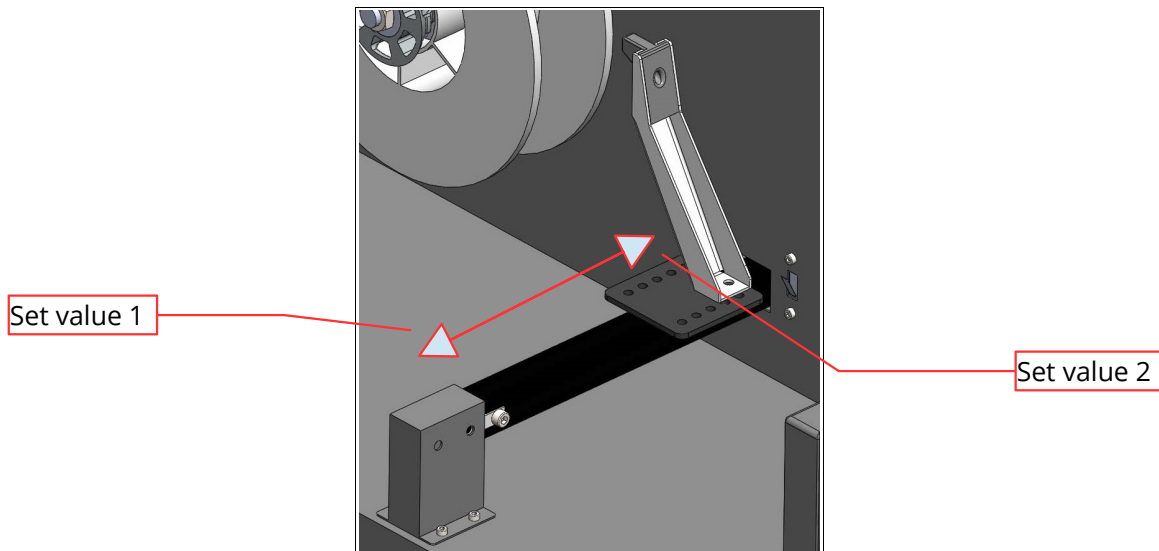
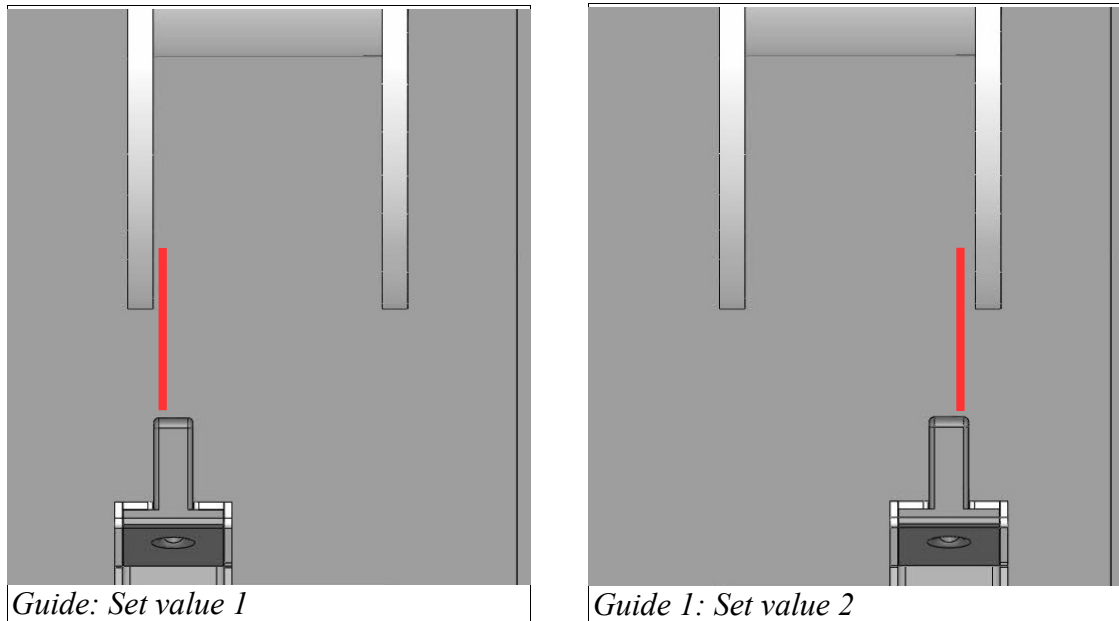

Image 3: Set new spool



STEP 4.2. Manual mode - set filament width:

Here you can enter the diameter of filament you are using with the winder 2.0 (**Image 4**). There is a pre-set of 1.75mm and 3mm however you can change this to a custom value between 0.5mm and 5mm. The algorithm automatically adjust the speed at which the guide moves accordingly. Press the "**NEXT**" button to continue.

Image 4: Set diameter screen

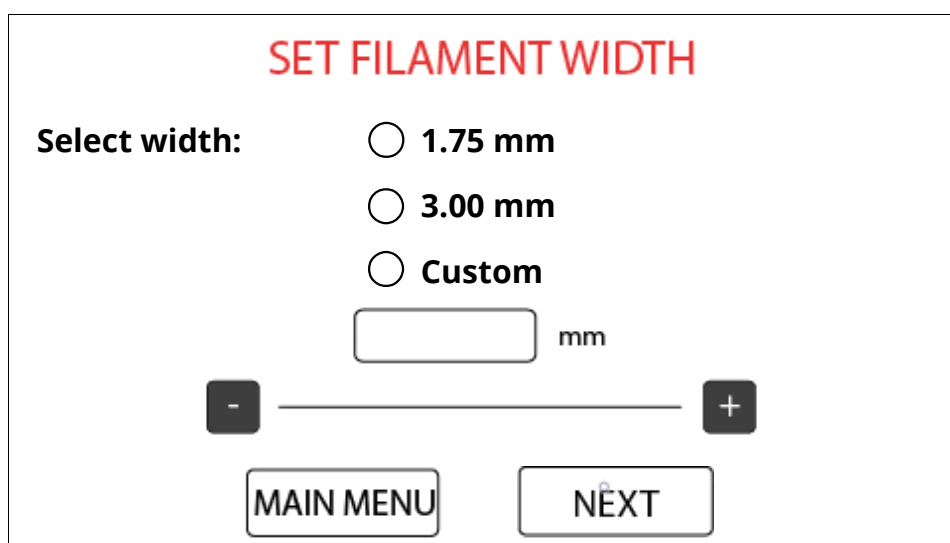

STEP 4.3. Manual mode - set motor speed:

On this page, input your preferred motor speed within the range of 50-250. The motor will maintain a constant speed throughout operation. You have the flexibility to adjust to a slower or faster speed even while the machine is running by revisiting the settings.

Image 5: Set manual speed

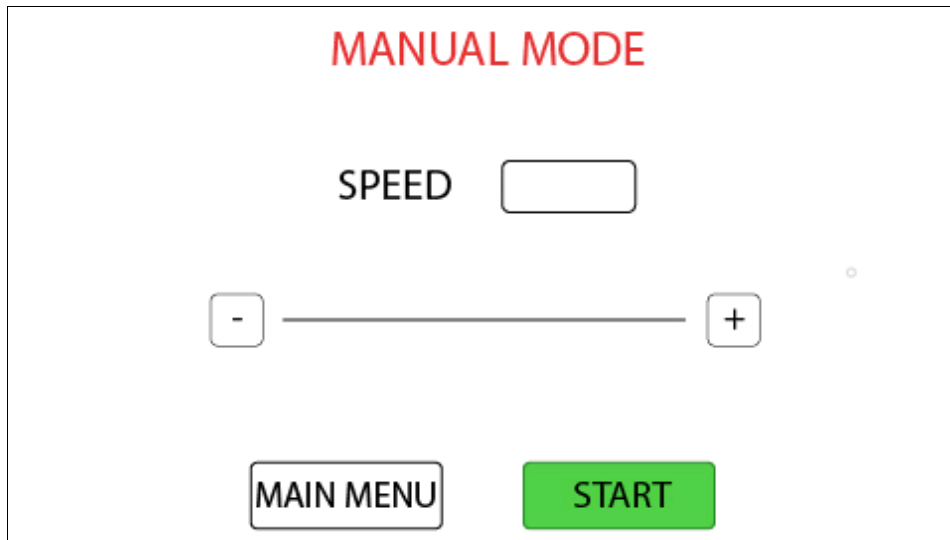

STEP 4.4. Manual mode - start:

After completing the previous steps, initiate your winding operation by pressing the start button. Before doing so, carefully read the next step (**Step 6.**) on correctly loading your filament onto the spool. If any adjustments to the settings are needed, you can always go back and make changes.

Automatic mode:

STEP 5.1. Automatic mode set guides:

Refer to step 4.1 in the Manual Mode setting section for detailed instructions on configuring the filament guide limits.

STEP 5.2. Automatic mode set filament width:

Refer to step 4.2 in the Manual Mode setting section for detailed instructions on configuring the filament width settings.

STEP 5.3. Automatic mode calibrate sensor

In this step (**Image 6**), prepare a piece of filament or a similar item with the same diameter as the material you plan to wind. As the screen displays 'calibrating in progress,' slowly move the piece up and down through the sensor area (**Image 7**). Repeat this process until the calibration is complete.

Image 6: Calibrate filament screen

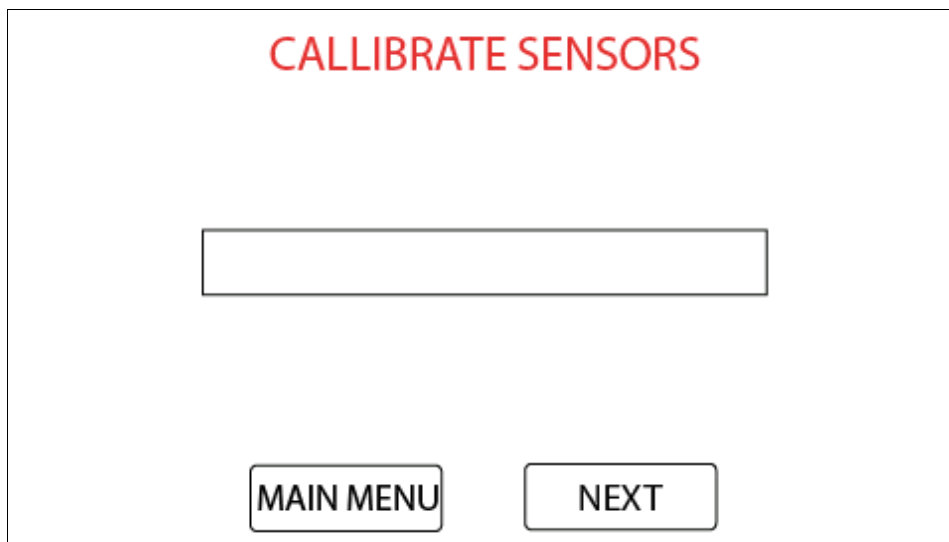
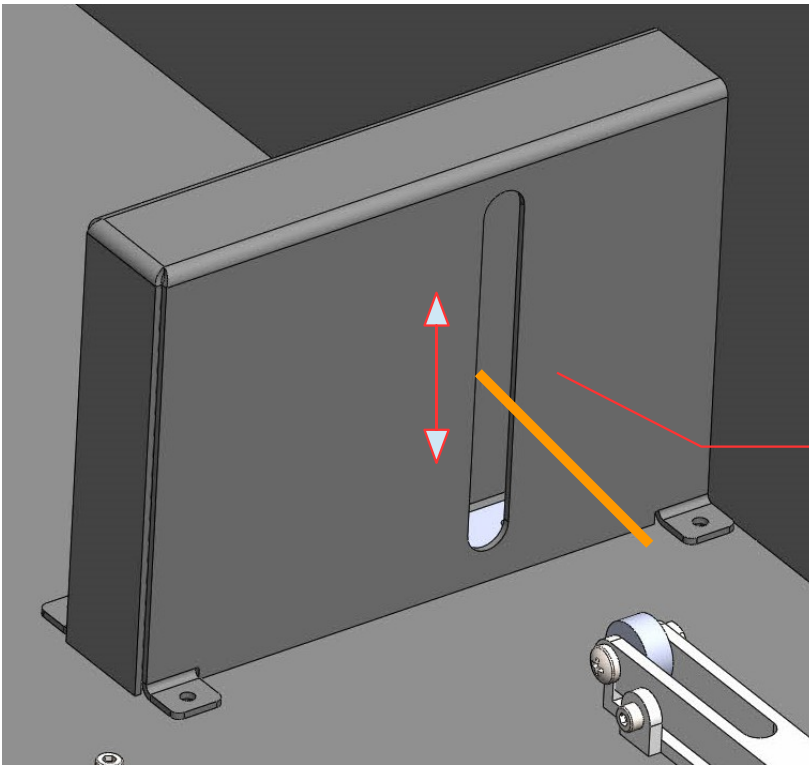

Image 7: Filament calibration.



Hold a piece of calibration filament or a similar item with your hand, ensuring it passes through both openings of the laser sensor.

The orange stroke in the image represents the calibration item. Ensure that the calibration piece aligns with the depicted orange stroke as you follow the calibration process.

When you press "calibrate" on the touchscreen, gently move the calibration piece up and down as directed by the arrows in the accompanying image.

STEP 5.4. Automatic mode start

After completing the previous steps, initiate your winding operation by pressing the start button. Before doing so, carefully read the next step (**Step 6.**) on correctly loading your filament onto the spool. If any adjustments to the settings are needed, you can always go back and make changes.

STEP 6. Filament loading procedure:

This section provides instructions on loading the filament onto the spool, serving as the final step before starting the machine for filament spooling.

Image 8: Filament loading.

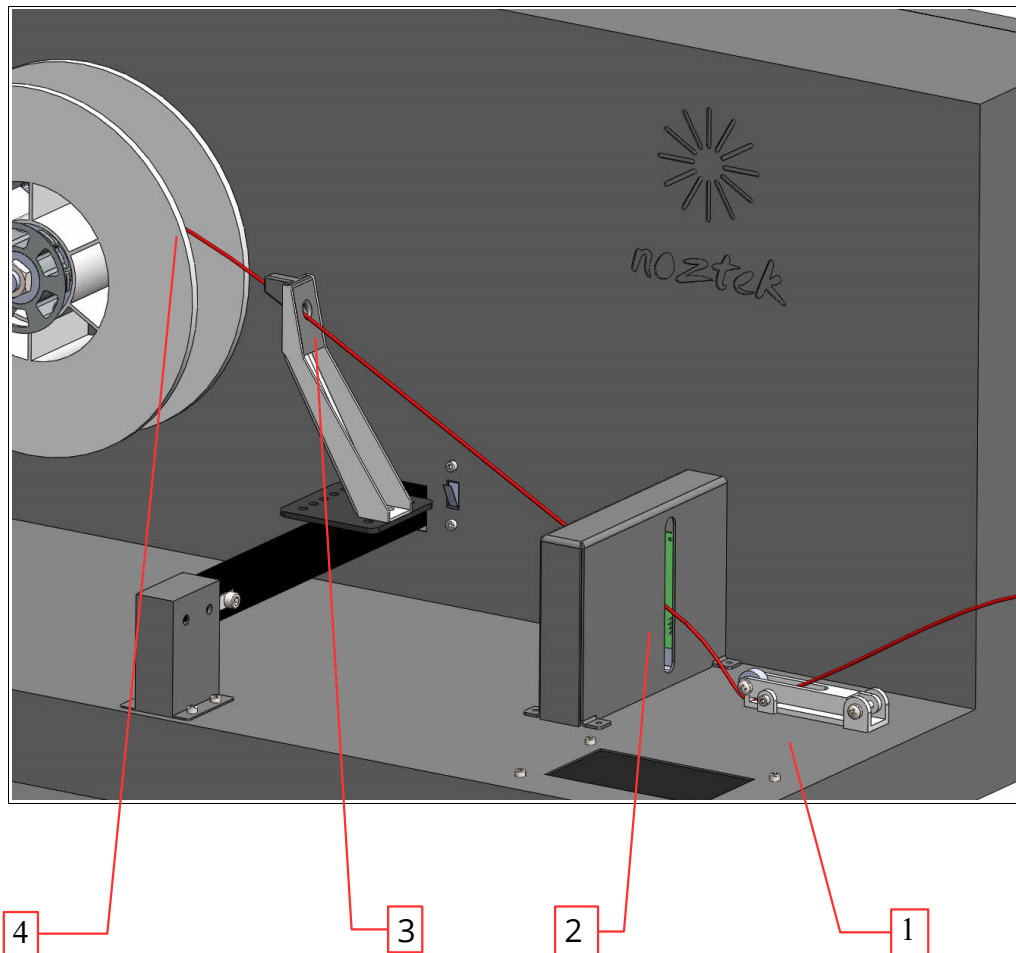

Loading filament steps.

1. Pull the filament under the tensioner: begin by pulling the filament under the tensioner to ensure proper tension during the winding process.
2. Thread the filament through the laser sensor case.
3. Feed the filament through the opening in the filament guide.
4. Secure the filament on the spool: fasten the filament securely onto the spool. Utilize the side of the spool that is closest to the guide for optimal winding.
- 4.1 On each side of the interior of the spool, small holes are positioned (**Image 9**). These holes serve as anchor points for feeding in your filament before initiating the winding process. Alternatively, you can use tape to secure the filament to the spool. Always begin at an edge corner of the spool for optimal results. This ensures a reliable starting point for the winding process.

Image 9: Securing filament.

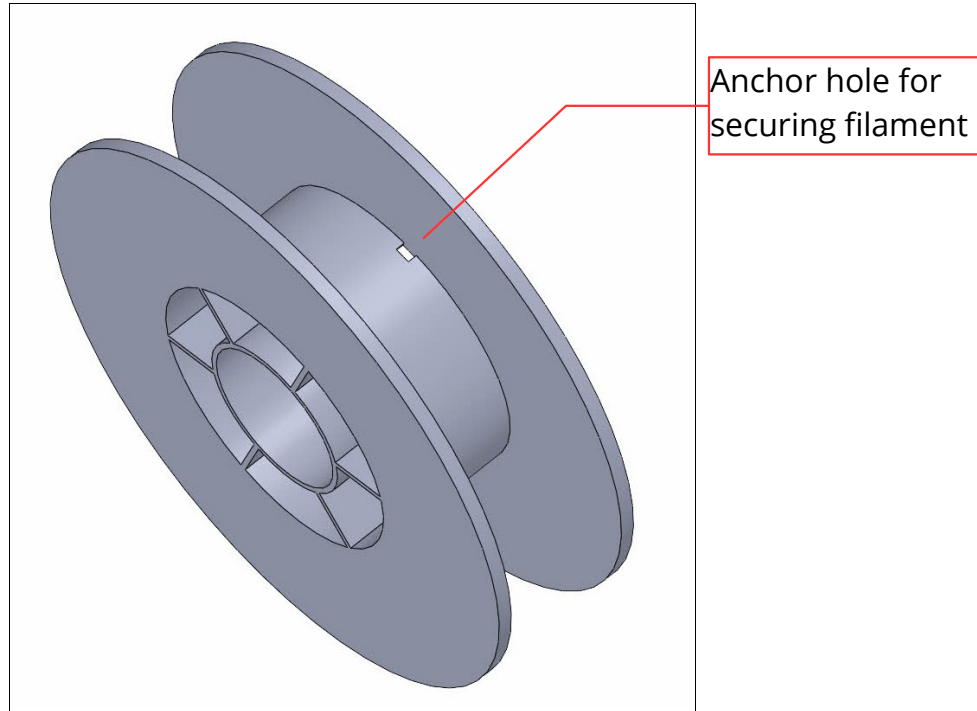

5. Initiate the winding process:
With everything in place, press the start button to commence the winding process. **(Image 10)** If you wish to modify any settings, you have the flexibility to do so at any time. On this screen, you can press each individual button to navigate back into the respective setting and make adjustments as needed. If you need to halt the winding process at any point, such as when the spool is full, simply press the red stop button.

Image 10: Filament loading.

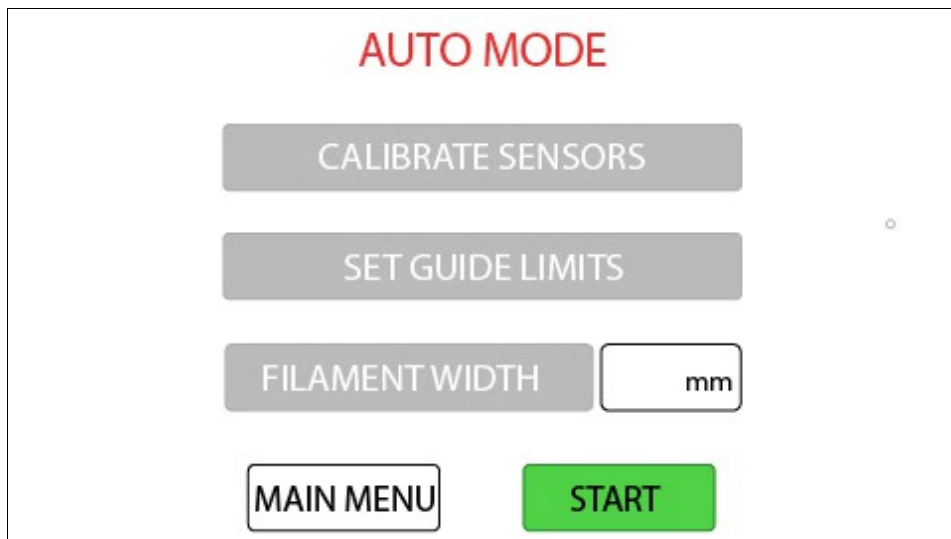

STEP 7. Shutdown Procedure:

When finished, turn off the MAINS POWER SWITCH located at the back of the machine. These instructions ensure safe and efficient operation of the Noztek Winder 2.0.

Additional information

1. Changing the spool.

Once your spool is full after the winding process, follow these steps:

1. Press the stop button on the touchscreen in either manual or automatic mode.
2. Use a spanner to loosen the locknut, as demonstrated in the accompanying image (**Image 11**).
3. Remove the nut, spool holder, and the full spool.
4. Take a new spool and reassemble it with the nut and spool holder onto the rod.
5. Use the spanner to secure the nut in place. Exercise caution not to over-tighten; instead, tighten the nut while rotating the spool with your hand. If the spool stops rotating, you've applied sufficient force.

Image 11: Filament loading.

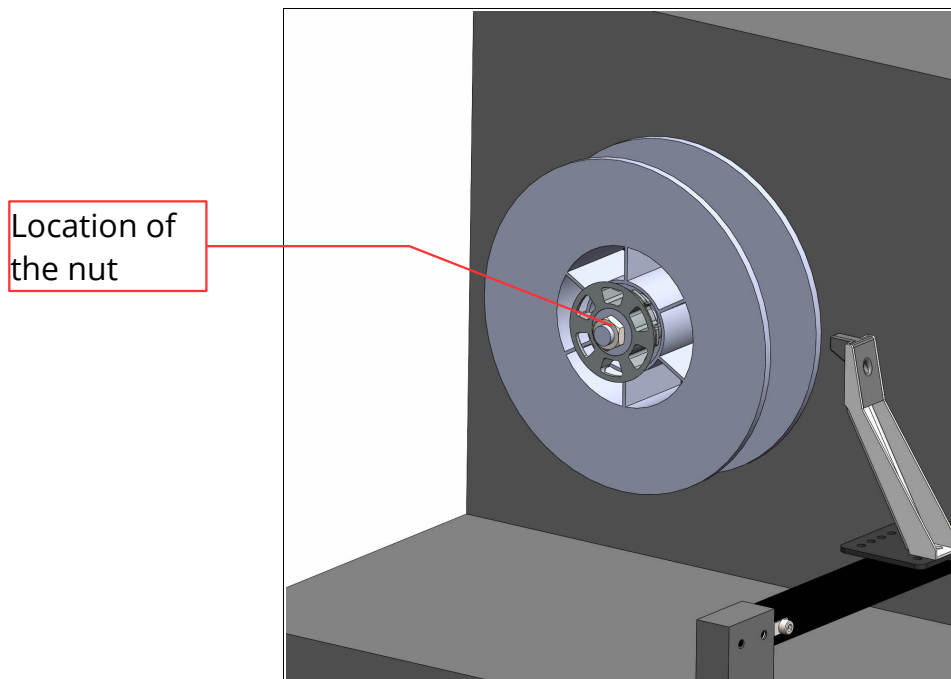

Contact noztek

For more in-depth troubleshooting assistance, we encourage you to explore our FAQ help section on our website at www.noztek.com. In the event that your specific query is not addressed within this resource, please do not hesitate to reach out to our dedicated Noztek expert team for direct support and guidance.

Noztek Ltd
Unit C3 Dolphin Industrial Estate Evershed Way,
Shoreham by Sea,
West Sussex,
BN43 6QB, ENGLAND

44 (0) 203 384 6208
info@noztek.com
www.noztek.com